

A Retrospective View on Automatic Tyre Inflation System

Debabrata Panda*, Amit kumar Sahoo**, Debasish Acharya***

& P.Gouri Prasad****

Department of Mechanical Engineering, Gandhi institute of Engineering And Technology, Gunupur, India.

ABSTRACT:

In older days, after the discovery of wheel by humans, it has been used extensively for various purposes and it is vital part of human life for ages. These wheels runs human life faster and faster with new technology and one such technology is on board air inflation system used in automobiles. Tyres are the second-highest cost for the trucking industry. The on board air inflation system is used to maintain the pressure of tyres in running condition. The environmental conditions varies according to region, seasons because of this, it require maintaining the tyres pressure for better performance according to conditions. Driven by studies that show that a drop in Tyre pressure by just a few PSI can result in the reduction of gas mileage, tyre life, safety, and vehicle performance, we have developed an automatic, self-inflating tyre system that ensures that Tyres are properly inflated at all times. Our design proposes and successfully implements the use of a centralized compressor that will supply air to all four Tyres via hoses and a rotary joint fixed between the wheel spindle and wheel hub at each wheel. The rotary joints effectively allow air to be channeled to the Tyres without the tangling of hoses. With the recent oil price hikes and growing concern of environmental issues, this system addresses a potential improvement in gas mileage; Tyre wear reduction; and an increase in handling and Tyre performance in diverse conditions.

Key words: PSI, Compressor, Rotary joints, Tyre Wear, Inflation

I. INTRODUCTION

It consists of a compressor, which supplies air when the pressure of the tyre decreases from the maximum limit and air tank is used to stored air at constant pressure. The pressure of the system can be compared by the standard value by the help of pressure sensor connected to the filling line. This pressurize air can be filled into tyres through flexible ducting with the help of rotary bearing. The pressure conditions are achieved by pressure gauges.

II. PROBLEM IDENTIFICATION

When tyres are under inflated, the thread wears more quickly. This equates to 15 percent fewer miles you can drive on them for every 20 percent that they're under inflated. Under inflated tyres also overheat more quickly than properly inflated tyres, which cause more tyre damage. The faded areas below indicate area because tyres are flexible; they flatten at the bottom when they roll. This contact patch rebounds to its original shape once it is no longer in contact with the ground. This rebound creates a wave of motion along with some friction. When there is less air in the tyre, that wave is larger and the friction created is greater -- and friction creates heat. If enough heat is generated, the rubber that holds the tyre's cords

together begin to melt and the tyre fails. Because of the extra resistance on under inflated tyre has, when it rolls, your car's engine has to work harder. Statistics show that tyres that are under inflated by as little as 2 psi reduce fuel efficiency by 10 percent.

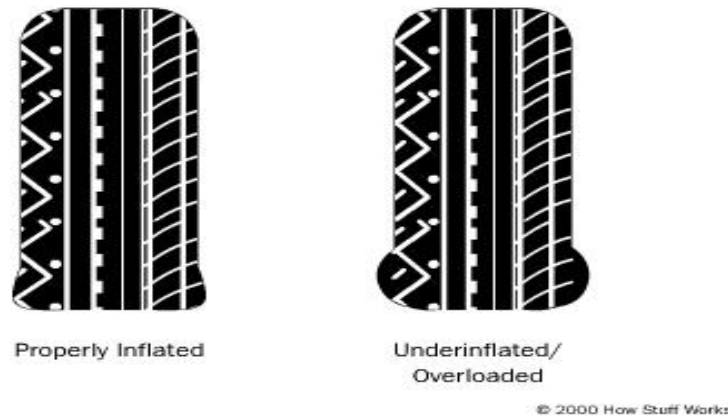

Fig. 1: Tyre inflating conditions

III. METHODOLOGY

This project started with discussion with project guide about design. This discussion covering project overview and throw out opinion that related about title and instruct to proposed a certain design and concept before go up to next step. Then we start to make and decide the best idea about the title. Before that, literature review and research about title is the important point to get the best idea. Then study and make a lot of investigation about conventional air filling system. This includes a study about concept of conventional air filling system, process to fabricate, and material. These tasks have been done through study on the internet, books, and others information.

After gather and collect all related information and obtain new idea and knowledge about the title, the project would continue with the design process. In this stage, the knowledge and idea should throw out in sketching process. After several design sketched, the best design would be choose among previous design so that we could carry on designing process. Then the selected design would be transfer to engineering drawing using CAD software in order to for analysis process. After that material preparation which is has been confirm initially. Purpose of this process is to determine the suitable and follow the product and design requirement. This process covering purchased material, measuring material and cutting off based on requirement. Here, this process is important because the material would determine whether our product in way to failure or otherwise.

After all the drawing and material preparation done the next process is a fabrication process. This process based on dimension has been determined from drawing. During this process, all the manufacturing process which is suitable could be used such as drilling process, thread using lathe machine, welding process and cutting material using disc cutter. Analysis stage has been implemented before fabrication stage. The evaluation is by considering the strength, portable, durability, safety and others. After all process above done on schedule without any problem such as product defect all material for report writing is gathered.

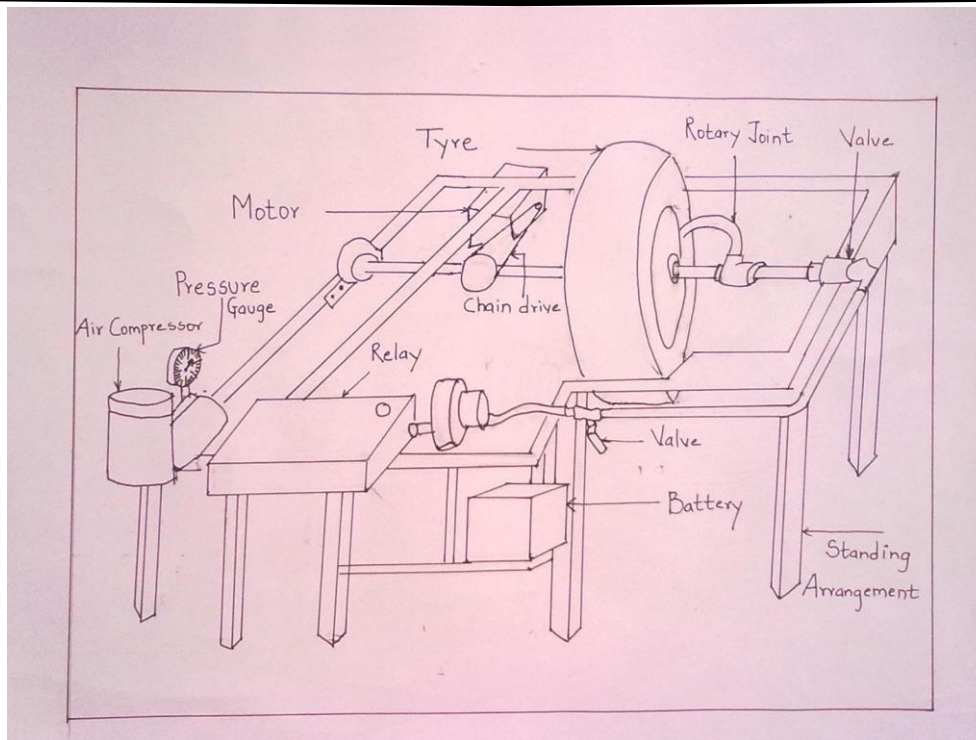

Figure 2: Schematic Layout of the design of inflation system

A. Selection of Parts:

- Air Compressor
- Car wheel or Rim
- Axle of car
- Flexible Ducting
- Rotary Joint, Valve
- Electronic components such as Pressure sensor, relay,
- Tyre
- Pedestal Bearing
- Coupler or Two-way valve
- Nuts and Bolts
- frame

IV. WORKING

In the process of automatic tyre Inflation system, the compressor is used to compress the air. The air is taken from the atmosphere and compressed it at required pressure. There is ducting which is used connect to the compressor outlet port and one end of the rotary joint through the relay. The compressed air is supplied to the rotary joint through the ducting. Two Pedestal bearings are used to support the axle of the assembly. Bearings are fixed to the rigid supports via nuts and bolts. The axle is rotate on which wheel or rim is mounted on one end. One end of coupler is connected to axle and other end is connected to rotary joint.

There are electronic sensors are used to detect the tyre pressure with the help of pressure gauge. When the air pressure in the tyre reduced below the required level then the sensors senses

the pressure level and send feedback signal to compressor for maintaining pressure level of the air in the tyre. Compressor works on the 12V battery of the vehicle and it is reciprocating in nature that's why it's easy to obtain the desired pressure level. Rotary joint is used to rotates well as to supply compressed air simultaneously when requires.

A. Advantages:

- Reduced tyre blowouts since tyres remain at the proper inflation level at all times.
- Reduce maintenance cost and time efficiency.
- Reduce human efforts.
- Increase the vehicle efficiency.
- Increase the life span of tyre.
- Avoids accidents and fatality.

B. Applications:

- It can be used in military vehicles.
- It can be used in emergency vehicles like ambulance, police vehicles and fire vehicles.
- It can be used in trucks and trailers.
- It can be used in very costly vehicles where maintenance of standard is important.
- It can be used in sports cars as there is need of regular checking of air pressure in tyres.

V. RESULT AND CONCLUSION

We applied all these techniques to reduce the process time and human efforts of the conventional manual air filling system. The system helps to reduce cost and friction between surface of tyre and road so that will reduce the material, measuring material and cutting off based on requirement. Here, this process is important because the material would determine whether our product in way to failure or otherwise. Wastage of tyre material. As a result, it will increase the life of tyre.

After fabrication of automatic tyre inflation system, the result obtained that if the system utilization will be executed in proper by taking and concerning all the relevant according to the project demand the process time, cost and human efforts can be reduce in a great manner.

REFERENCES

- i. A Textbook of Machine Design by R. S. Khurmi & J. K. Gupta.
- ii. A Textbook of Automobile Engineering by Kripal Singh.
- iii. P. Omprakash, T. Senthil Kumar- "M.A.R.S - Mechanized Air Refilling System", International Journal of Information Sciences and Techniques (IJIST) Vol.4, No.3, May 2014.
- iv. Ajas. M.A, Aiswarya. T.G, Adersh Vinayak, Surya Balakrishnan, Janahanlal-"TYRE Pressure Monitoring and Automatic Air Filling System", IJREAT International Journal of Research in Engineering & Advanced Technology, Volume 2, Issue 2, Apr-May, 2014.

-
- v. Sivarao, T.J.S. Anand and M.Warikh- “Engineering of TYRE Pressure Controlling Device: An Invention Towards Successful Product Development”, International Journal of Basic & Applied Sciences IJBAS-IJENS Vol:09 No:09.
 - vi. Sadda. Mahendra1 , N. Amara Nageswara Rao- “Effect of Tyre Overload and Inflation Pressure on Rolling Loss (resistance) and Fuel Consumption of Automobile Cars”, International Journal of Computational Engineering Research (IJCER), October– 2014.

www.ijesta.com